

A typical Solectek Branching Circuit design — 1U rack mount unit for a 2+0 configuration

Introduction

PTP backhaul links can be implemented as simple as connecting two radio units. In some cases, customer applications demand using multiple radios. Some of these applications include provision of hot standby redundancy (1+1) and increasing the link capacity (2+0), which require combining, splitting, and routing of various signals transmitted/received by multiple radios.

A common configuration for multiple radio deployment is sharing of a single antenna for multiple radios. The reasons may be that the antenna and waveguide may already be installed at the site, tower spaces may be limited, or costs involved in tower climbs and logistics cannot be justified.

Yet, combination of two or more radios signals for this purpose is not a trivial task due to signal interference between them, which leads to severe performance degradation. One way of reliably routing various signals to intended receivers is to use a branching circuit, consisting of waveguide elements such as isolators/circulators and high rejection filters.

Branching Circuit Specifications

- Frequency Bands: 6 – 38 GHz
- Impedance: 50 Ohm
- Return Loss: 20 dB
- Insertion Loss (Primary): <1 dB
- Second Path Loss: 0.6 dB additional
- Circulator Isolation: 25 dB between ports
- Circulator Loss: 0.1 dB per pass
- Filter Rejection: up to 80 dB, out of band
- Interface to Radio/Ant waveguide
 - Coax (low freq) or waveguide flange
- Waveguide Interface (waveguide/flange)
 - 6 GHz: WR-137 / CPR-137G
 - 7/8 GHz: WR-112 / CPR-112G
 - 11 GHz: WR-90 / CPR-90G

Branching Circuits

A typical block diagram for a branching circuit is shown below.

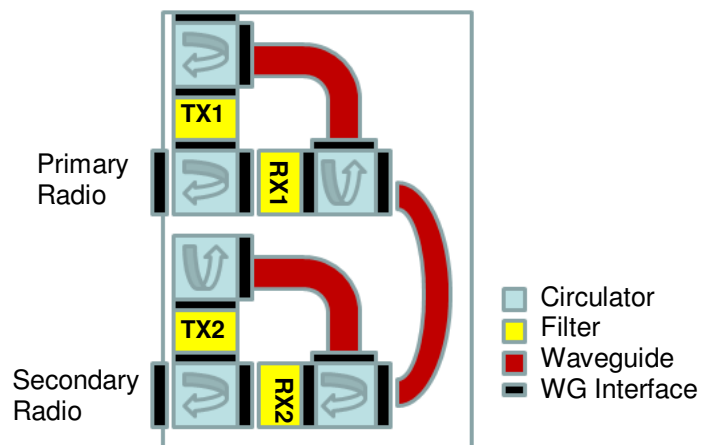

In this branching circuit, circulators act as signal routers for all four signals (Tx1, Rx1, Tx2, and Rx2). Narrowband filters are deployed at various points to reject all incoming signals except that intended for the receiver behind it. The key to performance is the filter design – high rejection is required to insure that highest level of performance in the link, especially for 128/256QAM modulation being used today.

Solectek can design branching circuits to fit the need for customer's frequency channel and performance requirements. Please inquire Solectek sales for details.

Solectek Corporation
 6370 Nancy Ridge Dr. Suite 109
 San Diego, CA 92121
 858.450.1220
 sales@solectek.com
 www.solectek.com